

## SMB COMBI › Assembling Machine

Technical data / Dati tecnici	SMB COMBI	SMB
	Plunging, labelling and assembling	Assembling of Back Stop
Performance (syringes/min) / Velocità produttiva (siringhe/min)	Up to 400	Up to 400
Installed power (kW) / Potenza installata (kW)	15	6
Basic Machine Weight (kg) / Peso macchina base (kg)	2800	1000

### SMB COMBI

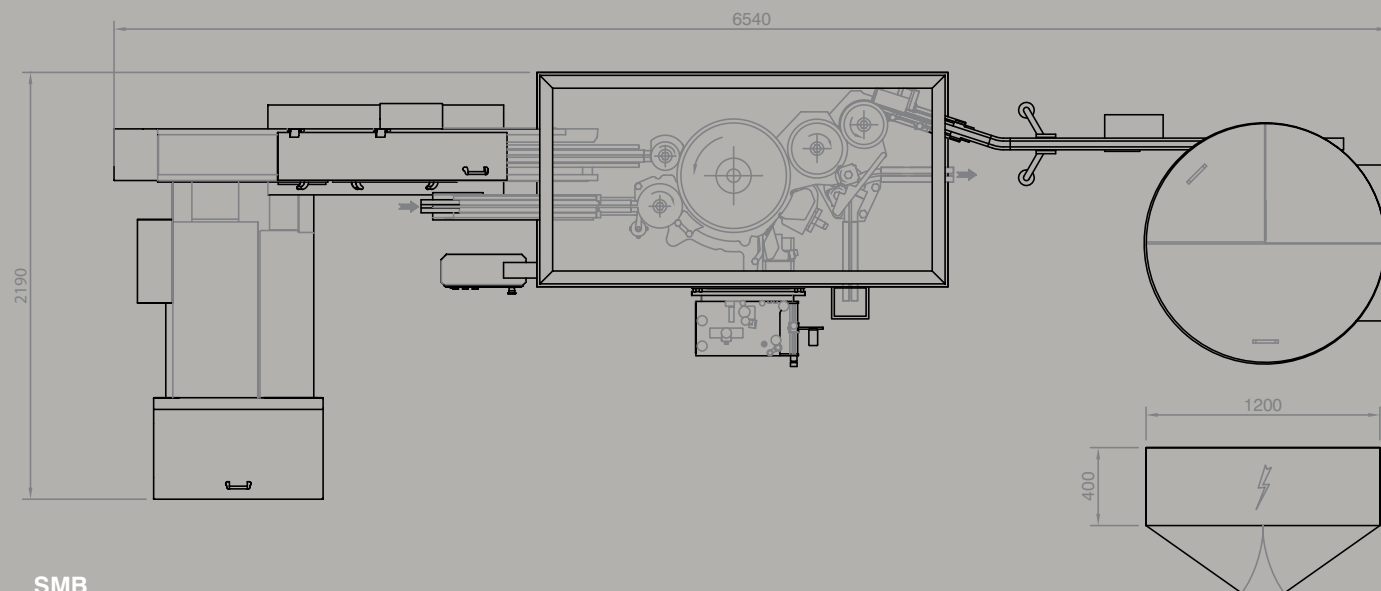

### SMB

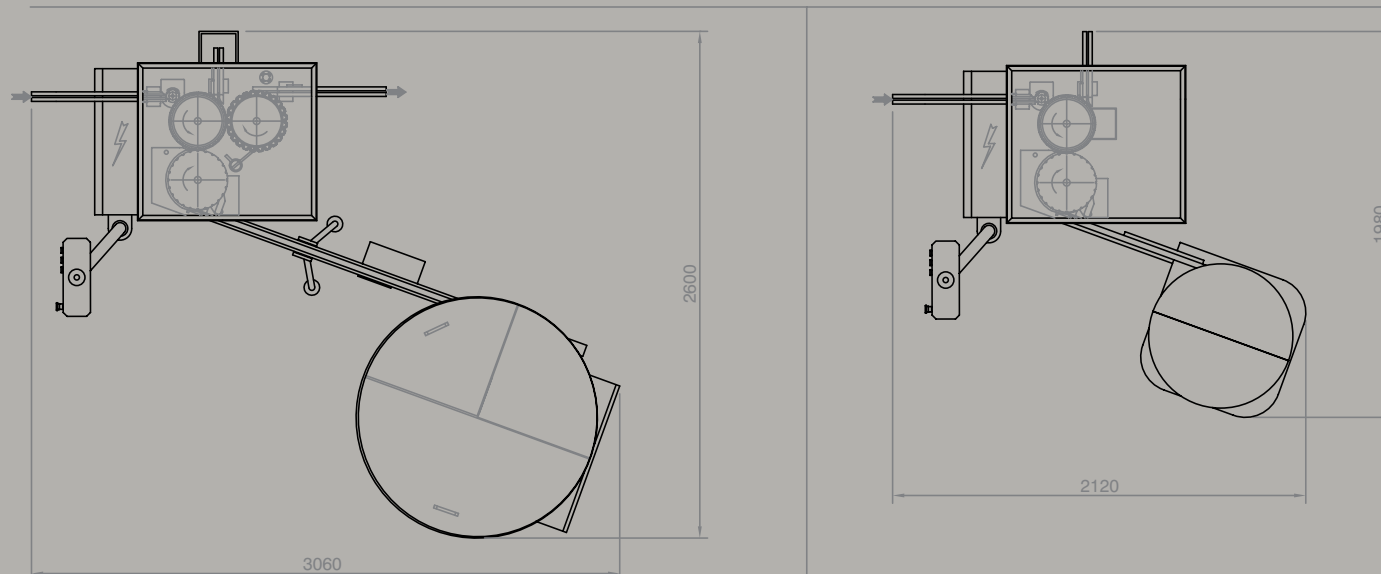

Size range may change in accordance with the different applications.

I limiti di formato possono cambiare a seconda delle diverse applicazioni.

Marchesini Group is continuously update their products to market needs.

Marchesini Group adatta costantemente i propri prodotti alle esigenze del mercato.

The technical specifications given hereby are subject to change without prior notice or without liability.

Le specifiche tecniche qui riportate sono perciò suscettibili di cambiamento.

**Corima S.r.l.**  
Strada delle Frigge, 15  
53035 Monteriggioni - Siena - Italy  
tel +39 0577 17 490 11 - fax +39 0577 31 82 09  
info.corima@marquesini.com - www.marquesini.com

Headquarter:  
**Marchesini Group S.p.A.**  
via Nazionale, 100  
40065 Pianoro - Bologna - Italy  
tel +39 051 65 187 11 - fax +39 051 65 164 57  
sales@marquesini.com - www.marquesini.com



Design: Argento e China - ph. A. Cocchi / C. Bertolini

## SMB COMBI

## Assembling Machine for syringes

SMB



Liquids  
Solids  
Creams  
Packaging

English / Italiano

Edition May 2009 - Printed by www.tipollografic.com



## SMB COMBI

Machine for plunging, labelling and assembling of syringes with Back Stop.

Building principles, used materials together with our technological innovations guarantee high quality, simplicity of use and make the SMB COMBI machine a perfect solution for the pharmaceutical field requirements.

### **General Features:**

- Ability to work with any type of Back Stop
- Minimum space required for installation
- Flexible connection with downstream and upstream machines
- Brushless motorizations designed for the various functions of the machine allowing the widest operative management.
- Operator interface equipped with Touch-Screen colour PC



- Syringes automatic loading by a roller gate
- Plungers automatic loading by an elevator and a roller gate
- Back Stop automatic loading by an elevator conveyor belt
- Screwing group completely adjustable
- System for labels feeding and application

- Carico automatico delle siringhe mediante rulliera
- Carico automatico delle astine mediante elevatore e rulliera
- Carico automatico dei Back Stop mediante elevatore e nastro
- Gruppo avvitatura completamente parametrizzabile
- Sistema di alimentazione ed applicazione etichette

- External labelling group completed with unwinding group, print housing and label support winder
- Label reel control and management

- Gruppo etichettatrice esterno completo di gruppo svolgitore, alloggiamento stampante e riavvolgitore del supporto etichetta
- Controllo e gestione della bobina delle etichette



- External labelling group with double winding group
- Double printing system available

- Gruppo etichettatrice esterno con doppio gruppo svolgitore
- Possibilità di doppio sistema di stampa



## BACK-STOP >

- Machine for the assembling of back-stops with syringes
- Back-stop automatic loading
- Assembled syringe unloading on guide

- Macchina per l'assemblaggio di back-stop con siringa
- Carico automatico dei back-stop
- Scarico della siringa assemblata su guida

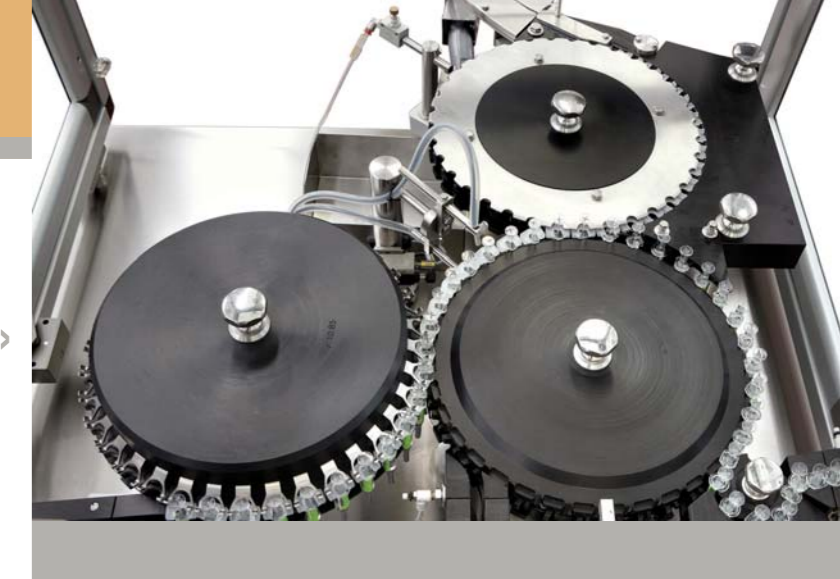

## SMB >

Double back-stop assembling allowed

Possibilità di assemblaggio con doppio back-stop



## SMB COMBI

Macchina astinatrice, etichettatrice e assemblatrice di siringhe con Back Stop.

I principi costruttivi, i materiali utilizzati e le innovazioni tecnologiche impiegate assicurano qualità, semplicità di utilizzo e rendono la macchina SMB COMBI una soluzione ideale per soddisfare i requisiti del mondo farmaceutico.

### Caratteristiche generali:

- Capacità di lavorare tutti i tipi di Back Stop
- Minimo spazio di installazione
- Flessibilità di interfacciamento con macchina a monte e a valle
- Motorizzazioni Brushless dedicate alle varie funzioni macchina per permettere la più ampia gestione operativa
- Interfaccia operatore equipaggiata con PC dotato di Touch-Screen a colori



High flexibility and ability to work with any type of back-stop

Elevata flessibilità e capacità di lavorare tutti i tipi di back-stop