

**FA10**

Stretch wrapping machine



Liquids  
Solids  
Creams  
**Packaging**

Italian/English

## Description

The **FA10 series** are balcony style wrapping machines totally based on GMP norms, suitable for pharmaceutical industry needs.

### Main features:

- Machine's main movements, driven by servomotors are located behind machine's frame.
- Very compact design
- Easy inspection of all areas involved in the packaging product flow
- Low maintenance
- Available in three different web sizes: 210-300-500mm
- Two work flow options: in line or 90° feeding

### Optionals:

- Automatic reel splicer without stopping machine
- Pusher with Comb-like movement
- Stacking unit driven by servomotor with variable stroke
- Exit belt for line clearance

## Layout

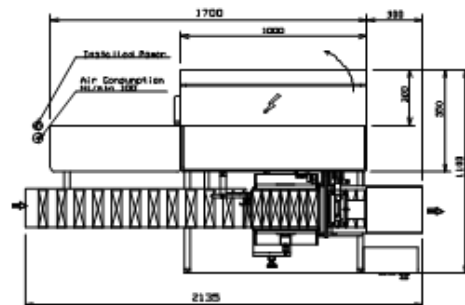
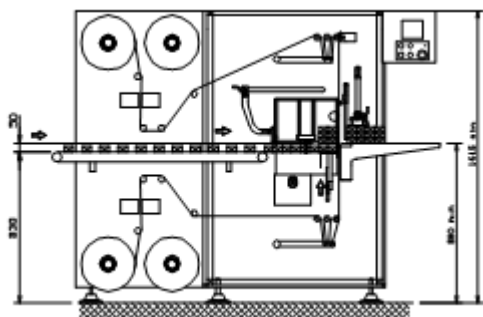

La **serie FA10** sono fardellatrici a balcone totalmente a norme GMP e quindi adatte alle esigenze del packaging farmaceutico.

### Caratteristiche generali:

- Movimenti principali della macchina azionati da servomotori posizionati sul retro del fronte macchina.
- Design estremamente compatto.
- Facile ispezionabilità di tutta la zona di flusso del prodotto
- Manutenzione ridotta al minimo.
- Disponibile in tre diverse fasce di prodotto: 210-300-500mm
- Due versioni di alimentazione: in linea o 90°

### Optional:

- Giunzione automatica del film di scorta senza arresto macchina.
- Spintore con movimento a pettine.
- Gruppo impilatore con servomotore a corsa variabile.
- Nastro in uscita per svuotamento macchina

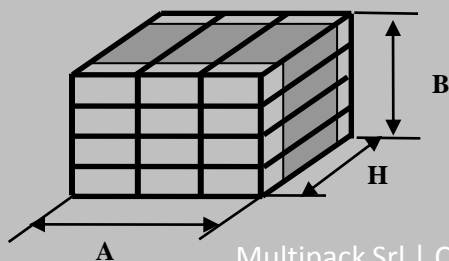

Size range (in mm) Gamma formati (in mm)	Technical data Dati tecnici	
Bundle dimensions Dimensioni fardello	FA10	
A = 30 - 350	Speed/Veloc.	Up to 50 Cycle
B = 12 - 220	Weight/Peso	Up to 1500 Kg
H = 50 - 200 (300-500)	Power/Potenza	Up to 7,5 Kw