



PS310 | Incartonatrice Semi-Automatica



Liquids
Solids
Creams
Packaging

italiano

Layout

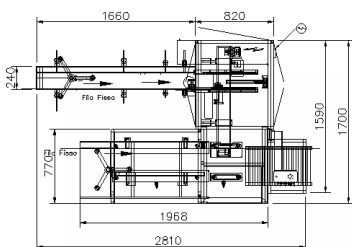
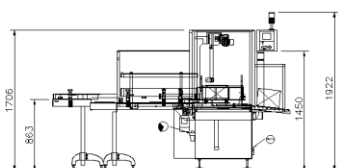

Gamma formati

A1	140-450 mm
B1	110-350 mm
H1	75-250 mm
A	25-440 mm
B	10-140 mm
H	65-180 mm

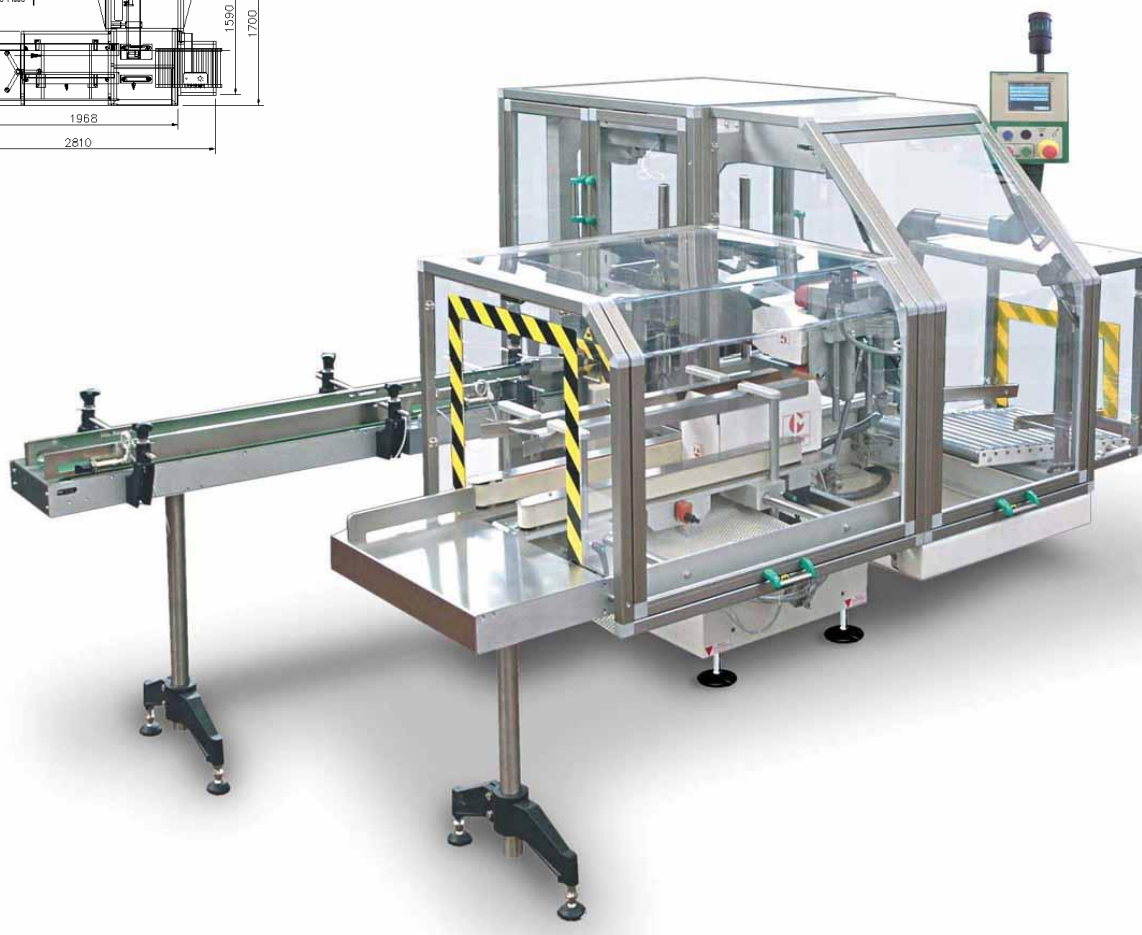
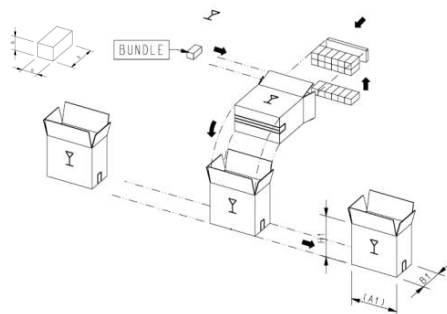

PS310 | Incartonatrice Semi-Automatica

Incantatrice Semi-automatica studiata per chi, pur non necessitando di una soluzione completamente automatica, cerca una certa autonomia di funzionamento e condizioni di lavoro in sicurezza. I cartoni, infatti, vengono alimentati manualmente in un magazzino di attesa motorizzato: il sistema, quindi, gode di una certa autonomia e non richiede la presenza costante dell'operatore, che può così svolgere altre mansioni.

- Ampia gamma di formati Prodotti e Cartoni.
- Struttura cabinata con Carter di protezione antinfortunistica con micro di sicurezza a norma CE.
- Zona di alimentazione cartoni di massima sicurezza, assente da movimenti.
- Controllo sovraccarico di coppia su tutti i motori.
- Logica di Funzionamento controllata da PLC.
- Cambio formato facile e veloce, con indicatori digitali e parti mobili a fissaggio rapido.
- Predisposizione per interfacciamento con macchina a monte.

- Arresto macchina per carico minimo in alimentazione con ripartenza automatica.
- Zona di passaggio, impilamento e trasferimento astucci nel cartone completamente isolata, onde evitare la caduta dei prodotti all'interno della macchina.
- Display Alfanumerico per una facile interfaccia operatore.
- Composizione del raggruppamento impostabile a Display.
- Passaggio cartone completamente a balcone
- Velocità > fino a 6 cartoni/minuto



PS310 | Semi-automatic CasePacker



Liquids
Solids
Creams
Packaging

English

Machine layout

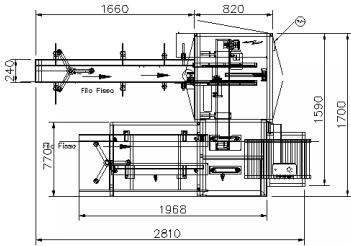
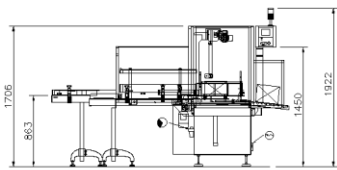

Size range

A1	140-450 mm
B1	110-350 mm
H1	75-250 mm
A	25-440 mm
B	10-140 mm
H	65-180 mm

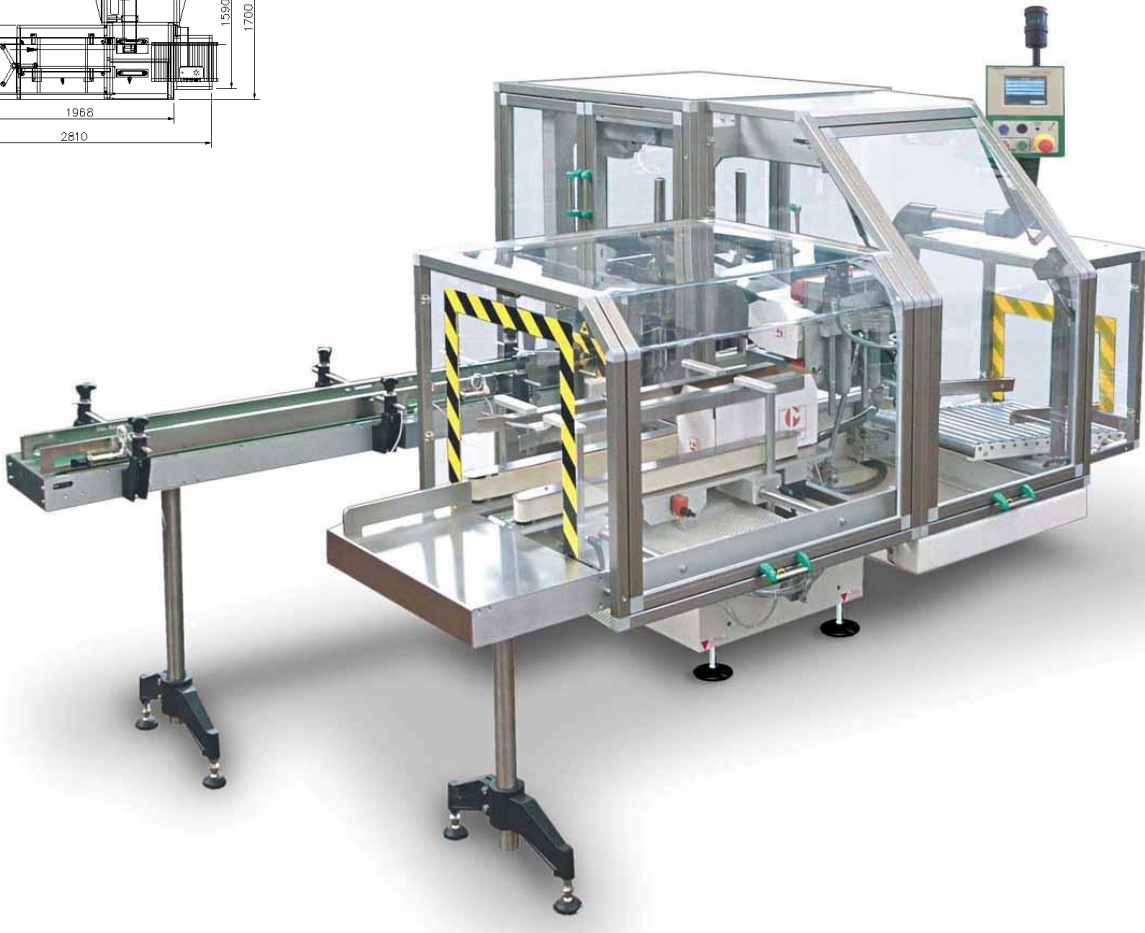
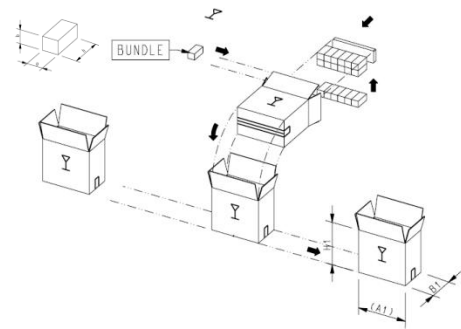

PS310 | Semi-automatic CasePacker

Semi-automatic Case Packer, designed and built to meet the requirements of safe working conditions and machine self-efficiency even to those who are not in need of a fully automatic solution. Pre-formed cases are manually fed on a motorised conveyor at the infeed: this ensures a certain independence of the machine, and leaves the operator free to carry on different jobs.

- Wide range of cases and products working sizes.
- Fully enclosed structure with Safety guards and security Micro to suit CE rules.
- Cases feeding area totally safe, free from any mechanical movement.
- Torque overloading control on every motor.
- PLC controlled functioning.
- Fast and easy change over, with digital indicators and quick fixing of mobile change parts.

- Already set for downstream machine coupling.
- Machine stop for minimum load at infeed with automatic re-start.
- Zone for carton transit, stacking and transfer into case, completely isolated to prevent products from falling into the machine
- Alphanumeric Display for easy operator interface.
- Setting of product stacking through Display.
- Completely balcony-style case transit
- Output: > up to 6 cases/minute